

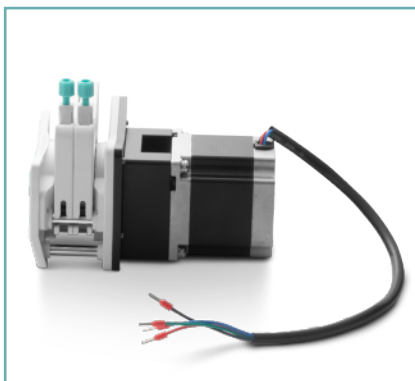

产品型号 : OEM-AMCB101

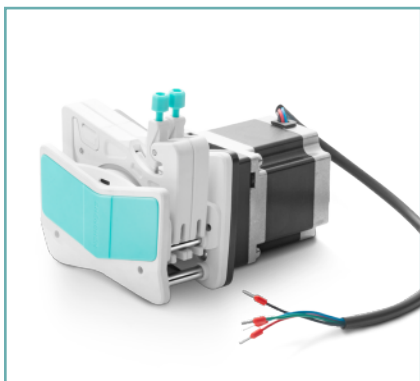

## 流量范围

AMC 系列多通道型泵头技术参数									
通道数	1	2	3	4	5	6	8	10	12
滚轮材料	304 不锈钢								
滚轮数量	10 滚轮, 6 滚轮								
适用软管	转速范围	10 滚轮泵头参考流量(mL/min)	6 滚轮泵头参考流量(mL/min)	软管承压(Mpa)					
				连续	间隔				
1×1	0.1~150rpm	0.0050~7.55	0.0062~9.36	0.1	0.1				
2×1		0.0183~27.52	0.0220~33.06						
2.4×0.8		0.0254~38.13	0.0319~47.81						
3×1		0.0323~48.38	0.0434~65.17						
0.13×0.86		0.0002~0.29	0.0002~0.31						
0.19×0.86		0.0003~0.44	0.0003~0.46						
0.25×0.86		0.0005~0.76	0.0005~0.80						
0.51×0.86		0.0013~2.00	0.0014~2.05						
0.89×0.86		0.0030~4.47	0.0031~4.65						
1.14×0.86		0.0061~9.16	0.0065~9.74						
1.42×0.86		0.0125~18.75	0.0142~21.28						
2.06×0.86		0.0197~29.60	0.0234~35.17						
2.79×0.86		0.0286~42.86	0.0372~55.77						



## 电机参数

产品型号	OEM-AMCB101
转速范围	0.1-150rpm
流量范围	0.0002-65.17mL/min
电机类型	57 步进电机
电机相数	2
电机步距角	1.8°
电机相电压	2.7V
电机相电流	3.0A
工作环境	0-40°C, 80%RH无凝露

## 尺寸图 (单位:mm)

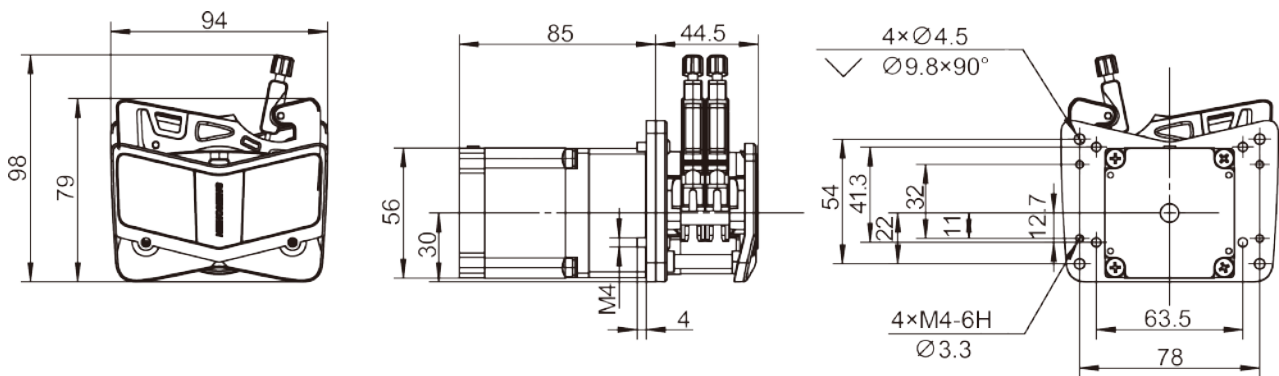

注:每增加或减少一个通道,泵头尺寸需要增加或减少一个卡片的宽度。

## 软管安装步骤



1. 轻松按压弹性锁臂机构,开启卡片。

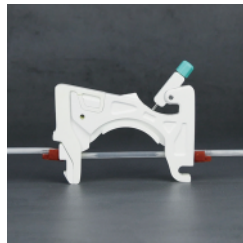

2. 卡片脱开之后,安装软管,相邻两个管卡确定一个工作位置。

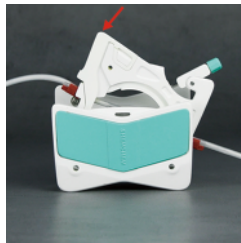

3. 嵌入卡片,使卡片进入工作位置。



4. 扳动压紧装置,进入压管状态。



5. 安装完毕。